

ALT6K

Automation for rod barriers up to 6 m



Management
System
ISO 9001:2008

www.tuv.com
ID 9105043769

TABLE OF CONTENTS

1	Safety warnings	pag. 3
2	Product Introduction	pag. 4
2.1	Technical characteristics	pag. 4
3	Preliminary Checks	pag. 4
4	Installing the Product	pag. 5
4.1	Installing	pag. 5
4.2	Release	pag. 5
4.3	Adjustment of rod angle	pag. 5
4.4	Inversion of direction of opening	pag. 5
4.5	Balancing	pag. 5
5	Testing and commissioning	pag. 6
5.1	Testing	pag. 6
5.2	Commissioning	pag. 6
6	Instructions and warnings for the final user	pag. 7
8	EC declaration of conformity	pag. 15

1 - SAFETY WARNINGS

WARNING

ORIGINAL INSTRUCTIONS - important safety instructions. Follow the instructions since incorrect installation can lead to severe injury! Save these instructions.

Read the instructions carefully before proceeding with installation.

The design and manufacture of the devices making up the product and the information in this manual are compliant with current safety standards. However, incorrect installation or programming may cause serious injury to those working on or using the system. Compliance with the instructions provided here when installing the product is therefore extremely important.

If in any doubt regarding installation, do not proceed and contact the Key Automation Technical Service for clarifications.

Under European legislation, an automatic door or gate system must comply with the standards envisaged in the Directive 2006/42/EC (Machinery Directive) and in particular standards EN 12445; EN 12453; EN 12635 and EN 13241-1, which enable declaration of presumed conformity of the automation system.

Therefore, final connection of the automation system to the electrical mains, system testing, commissioning and routine maintenance must be performed by skilled, qualified personnel, in observance of the instructions in the "Testing and commissioning the automation system" section.

The aforesaid personnel are also responsible for the tests required to verify the solutions adopted according to the risks present, and for ensuring observance of all legal provisions, standards and regulations, with particular reference to all requirements of the EN 12445 standard which establishes the test methods for testing door and gate automation systems.

WARNING

Before starting installation, perform the following checks and assessments:

ensure that every device used to set up the automation system is suited to the intended system overall. For this purpose, pay special attention to the data provided in the "Technical specifications" section. Do not proceed with installation if any one of these devices is not suitable for its intended purpose;

check that the devices purchased are sufficient to guarantee system safety and functionality;

perform a risk assessment, including a list of the essential safety requirements as envisaged in Annex I of the Machinery Directive, specifying the solutions adopted. The risk assessment is one of the documents included in the automation system's technical file. This must be compiled by a professional installer.

Considering the risk situations that may arise during installation phases and use of the product, the automation system must be installed in compliance with the following safety precautions:

never make modifications to any part of the automation system other than those specified in this manual. Operations of this type can only lead to malfunctions. The manufacturer declines all liability for damage caused by unauthorised modifications to products;

if the power cable is damaged, it must be replaced by the manufacturer or its after-sales service, or in all cases by a person with similar qualifications, to prevent all risks;

do not allow parts of the automation system to be immersed in water or other liquids. During installation ensure that no liquids are able to enter the various devices;

should this occur, disconnect the power supply immediately and contact a Key Automation Service Centre. Use of the automation system in these conditions may cause hazards;

never place automation system components near to sources of heat or expose them to naked lights. This may damage system components and cause malfunctions, fire or hazards;

WARNING

During cleaning, maintenance or during all operations requiring opening of the protective housings of various automation system components must be performed with the control unit disconnected from the power supply. If the disconnect device is not in a visible location, affix a notice stating: "MAINTENANCE IN PROGRESS":

connect all devices to an electric power line equipped with an earthing system;

the product cannot be considered to provide effective protection against intrusion. If effective protection is required, the automation system must be combined with other devices;

the product may not be used until the automation system "commissioning" procedure has been performed as specified in the "Automation system testing and commissioning" section;

the system power supply line must include a circuit breaker device with a contact gap allowing complete disconnection in the conditions specified by class III overvoltage;

use unions with IP55 or higher protection when connecting hoses, pipes or cable glands;

the electrical system upstream of the automation system must comply with the relevant regulations and be constructed to good workmanship standards;

users are advised to install an emergency stop button close to the automation system (connected to the control PCB STOP input) to allow the door to be stopped immediately in case of danger;

this device is not intended for use by persons (including children) with impaired physical, sensory or mental capacities, or with lack of experience or skill, unless a person responsible for their safety provides surveillance or instruction in use of the device;

before starting the automation system, ensure that there is no-one in the immediate vicinity;

before proceeding with any cleaning or maintenance work on the automation system, disconnect it from the electrical mains;

special care must be taken to avoid crushing between the part operated by the automation system and any fixed parts around it; children must be supervised to ensure that they do not play with the equipment.

WARNING

Do not use if repair or adjustment is necessary.

WARNING

The automation system component packaging material must be disposed of in full observance of current local waste disposal legislation.

WARNING

The data and information in this manual are subject to modification at any time, with no obligation on the part of Key Automation S.r.l. to provide notice.

2 - INTRODUCING THE PRODUCT

2.1 - Technical characteristics

TECHNICAL SPECIFICATIONS	900ALT624K
Torque	250 Nm
Temporary service	80 %
Opening time	6/*12 sec
Control unit	CT10224
Power supply	Vac (Vdc) 230 (24)
Motor absorption	1,3 A
Input power	300 W
Integrated lights	yes
Protection class	IP 54
Dimensions (L-P-H)	450-280-1188 mm
Weight	67 Kg
Operating temperature	-20 °C + 55 °C
Maximum length of bar	6*(8 mt)

* with 8 m bar

3 - PRELIMINARY CHECKS

Before installing the product, perform the following checks and inspections:

check that the barrier is suitable for automation;

the weight and size of the barrier must be within the operating limits specified for the automation system in which the product is installed;

check that the barrier has firm, effective mechanical safety stops;

make sure that the product fixing zone is not subject to flooding;

high acidity or salinity or nearby heat sources might cause the product to malfunction;

in case of extreme weather conditions (e.g. snow, ice, wide temperature variations or high temperatures), friction may increase, causing a corresponding rise in the force needed to operate the system;

the starting torque may therefore exceed that required in normal conditions;

check that when operated by hand the barrier moves smoothly without any areas of greater friction or derailment risk;

check that the barrier is well balanced and will therefore remain stationary when released in any position;

check that the electricity supply line to which the product is to be connected is suitably earthed and protected by an overload and differential safety breaker device;

the system power supply line must include a circuit breaker device with a contact gap allowing complete disconnection in the conditions specified by class III overvoltage;

ensure that all the material used for installation complies with the relevant regulatory standards.

4 - PRODUCT INSTALLATION

4.1 - Installation

Before proceeding with the installation, check the integrity of the product and that all components are present in the package.

1. Provide a foundation pit and arrange one or more conduits for the passage of the electrical cabling (Fig. 3).
2. Assemble the 4 anchoring brackets on the mounting plate and fasten with the 4 bolts provided.
3. Pour the concrete into the inside of the pit and position the base plate.

NOTE: verify that the plate is perfectly leveled and parallel to the opening barrier.

4. Wait for the complete setting of the concrete.
5. Unscrew the 4 nuts that hold the base joined to the anchoring brackets and position the rack on the plate (Fig. 4).
6. Attach the bar to the barrier body (Fig. 5).

ATTENTION: never move the barrier bar for any reason until it is horizontal, and do not perform the emergency or manual manoeuvre if the bar is not installed.

4.2 - Unlocking the bar

If you need to perform manual unlock on the barrier bar, proceed as follows (Fig. 8):

- Cut the power supply.
- Insert the release key provided and remove the latch (Fig. 8.1), insert the allen wrench and turn it 90° (Fig. 8.2).
- In this way you can detach the internal reduction system to allow the

emergency manoeuvre.

- Perform the manual manoeuvre.
- To engage the transmission again, turn the allen wrench back to its original position (Fig. 8.2) and close the lock (Fig. 8.3).
- You can now restore the power supply and check that everything is working correctly.

4.3 - Adjustment of bar angle

If you need to adjust the stops of the bar, proceed as follows (Fig. 6):

- Loosen the locking nut (on the rocker arm for ALT6).

- Adjust the screw to the desired height.
- Fasten the locking nut back in place.

4.4 - Inversion of direction of opening

- Turn off the power supply and, with the manual manoeuvre, place the bar vertical, restore the transmission and remove the bar to prevent hazardous conditions.
- Open the door, loosen the tension system of the springs and then release the springs from the upper fastening.
- Remove the fastening screws so as to free the springs in the upper

- part and allow them to be positioned on the opposite side of the fastening lever.
- Unscrew the lever so as to allow it to rotate and allow fastening of the springs in the opposite position.
- Fasten all in the indicated positions and tension the springs (see the paragraph on balancing).

4.5 - Balancing

- Cut the power supply.
- Release the bar.
- Position the bar at about 45°.
- Loosen the locking nut(s) of the spring tensioner(s).
If the bar tends to fall, adjust the spring tensioner(s) so that it is stopped (refer to the bar balancing table at the end of this manual).

- When balancing is complete, fasten the locking nut(s) again.
- Restore motorized operation by turning the release key in the opposite direction.
- Restore the power supply and check that everything works correctly.

5- TESTING AND COMMISSIONING THE AUTOMATION

The testing of the system must be performed by qualified technicians who must perform the tests required by relevant legislation related to risks, ensuring compliance with the provisions of the

regulations, in particular the EN12445 standard, which specifies the testing methods for the automation of doors and gates.

5.1 Testing

All system components must be tested following the procedures outlined in the respective instruction manuals.

Check that they meet the guidelines in Chapter 1 - Safety warnings
Check that the gate or door can move freely once the automation is unlocked, and that they are in equilibrium and stationary if left in any position.

Check the correct operation of all connected devices (photocells, sensitive edges, emergency buttons, etc.), testing the opening, closing and stopping of the gate or door via the connected control devices (transmitters, buttons, switches).

Carry out measurements of the impact force, as prescribed by standard EN12445 adjusting the functions of speed, motor force and deceleration of the unit if the measurements do not give the desired results until you find the right setting.

5.2 Commissioning

Following the successful testing of all (and not just some) devices in the system you can proceed with the commissioning.

You must prepare, and keep for 10 years, the technical file of the system with the wiring diagram, drawing or photo of the system, risks analysis and solutions adopted, manufacturer declaration of conformity of all devices connected, instruction manual of each device and maintenance schedule of the system.

Fix on the gate or door a plaque indicating the automation data, the name of the person responsible for the commissioning, the serial number and year of construction, the CE mark.

Attach a plaque indicating the steps required to manually unlock the system.

Implement and deliver to the end user the declaration of conformity, the instructions and warnings for use for the end user and the maintenance schedule of the system.

Make sure the user understands proper automatic, manual and emergency operation of the automation.

Inform the end user in writing of the dangers and risks still present.

6 - INSTRUCTIONS AND WARNINGS FOR THE END USER

Key Automation S.r.l. produces systems for the automation of gates, garage doors, automatic doors, shutters, parking lots and road barriers. However, Key Automation is not the manufacturer of your automation system, which is rather the result of a process of analysis, evaluation, selection of materials, and installation performed by your own installer. Each automated system is unique and only your installer has the experience and professionalism required to create a system to suit your needs, safe and reliable over time, and carried out in a workmanlike manner, i.e. compliant with the current regulations. Even if your automation system meets the security level required by law, this does not exclude the existence of "residual risks", i.e. the possibility that it may cause dangerous situations, usually as a result of improper or irresponsible use; for this reason we would like to give you some suggestions:

- Before using the automation for the first time, ask the installer to explain the origin of residual risks.
- Keep this manual for future use and deliver it to any new owner of the automation.
- Inappropriate or improper use of the automation can make it dangerous: do not command the movement of the automation if people, animals or things are in its range.
- Children: If properly designed, an automation system ensures a high degree of security, preventing movement in the presence of people or things with its detection systems, and ensuring always predictable and safe activation. It is prudent to prevent children from playing near the automation and keep remote controls out of their reach to prevent accidental activation.
- Malfunctions: As soon as you notice any malfunctions, disconnect the system from the power supply and operate the manual release. Do not attempt any repairs by yourself, but require the assistance of your installer: meanwhile, the system can operate like a non-automated opening device after releasing the motor reducer with the release key supplied with the system.
- In case of failures or power failures: While awaiting the arrival of your installer or the restore of the electricity, if the system is not equipped with backup batteries, the automation can be operated as any normal non-automated opening device. To do this, you must run the manual release.

Release and manual movement: before performing this operation pay attention that the device can be released only when the door is stationary.

- **Maintenance:** Like any machine, your automation needs periodic maintenance to ensure its long life and total safety. Agree with your installer on a maintenance plan on a periodic basis; Key Automation recommends a frequency of 6 months for normal domestic use, but this period may vary depending on the intensity of use. All inspection, maintenance or repairs should be performed only by qualified personnel.

- Do not change the system and control or programming parameters of the automation: the responsibility lies with your installer.

- The testing, routine maintenance and any repairs must be documented by the person who performs them, and related documents must be kept by the owner.

The only interventions that are possible for the user and should be carried out periodically are the cleaning of the slides and photocells, as well as the removal of any leaves or rocks that could hinder the automation. To prevent anyone from activating the gate or door, before proceeding, remember to release the automation and clean only with a cloth slightly dampened with water.

- **Disposal:** At the end of the automation useful life, make sure that the dismantling is carried out by qualified personnel and the materials are recycled or disposed of according to local regulations in force.

- Operate the gate or door (with remote control, key switch, etc.); if everything is working properly, the gate or the door will open and close normally, otherwise the flashing light flashes and the maneuver does not start.

With the safeties out of use, the automation must be repaired as soon as possible.

Replacing the remote control battery: if your remote control seems to work worse or not work at all after a while, this may simply depend on the exhaustion of the battery (depending on use, it may take several months to over a year). In that case, you will see that the confirmation of transmission light does not turn on, or comes on only briefly.

The batteries contain polluting substances: do not throw them in the garbage but use the methods prescribed by local regulations.

Thank you for choosing keyautomation; for more information feel free to visit our website www.keyautomation.it.

Fig. 1 - Space dimensions/Main components

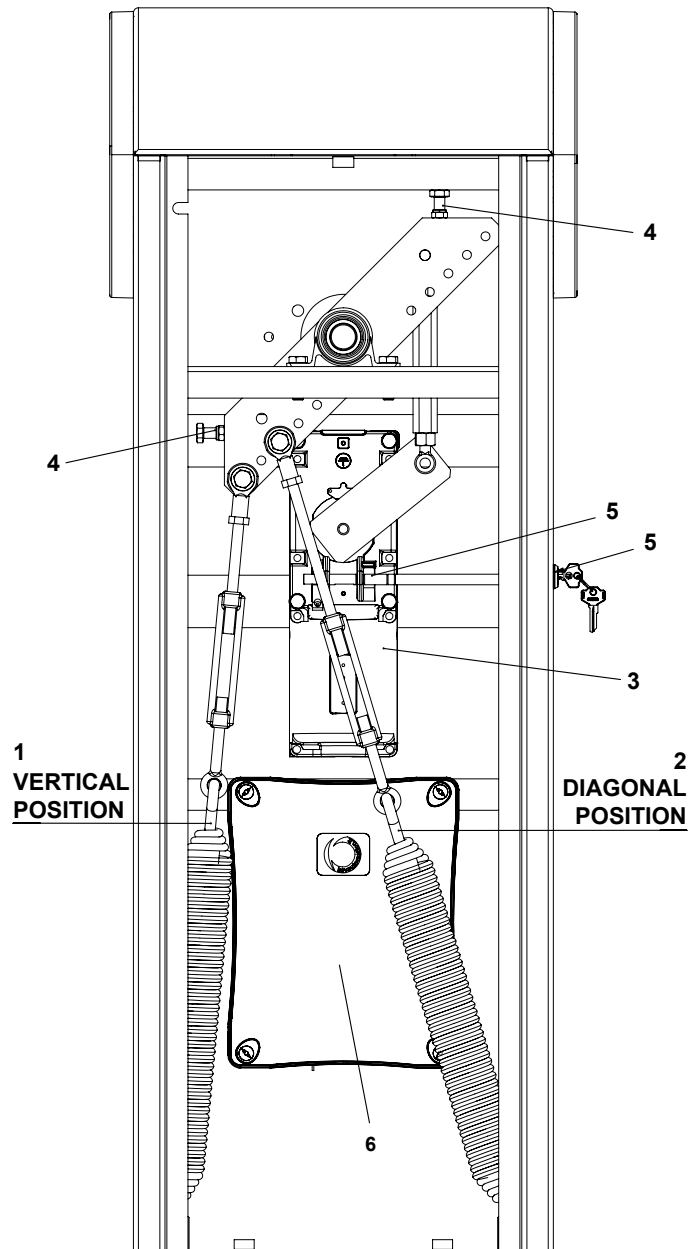
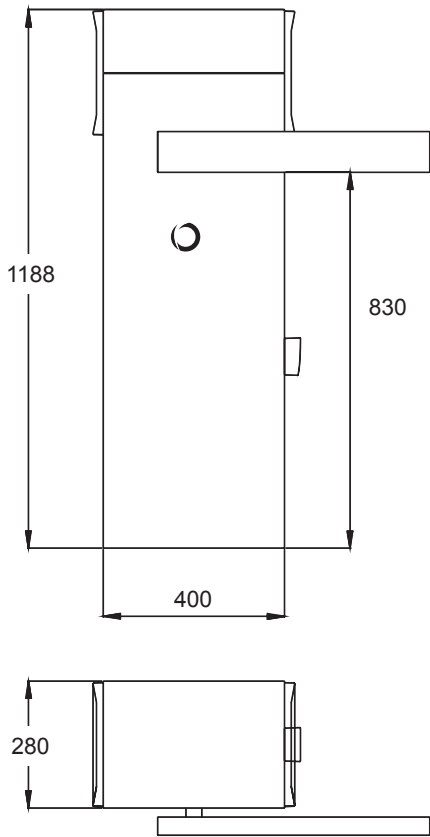

MAIN COMPONENTS	
1	SPRING + SHORT TIE ROD VERTICAL POSITION
2	SPRING + LONG TIE ROD DIAGONAL POSITION
3	MOTOR 24 Vdc
4	MECHANICAL STOP ADJUSTING
5	UNLOCK KEY
6	CONTROL BOARD

Fig. 2 - Typical Installation

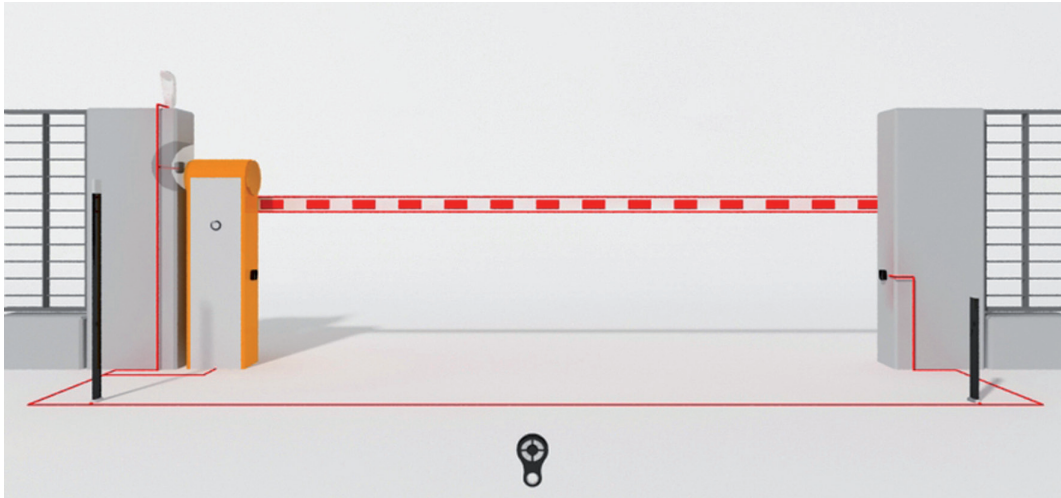

Fig. 3 - Preparation of the base

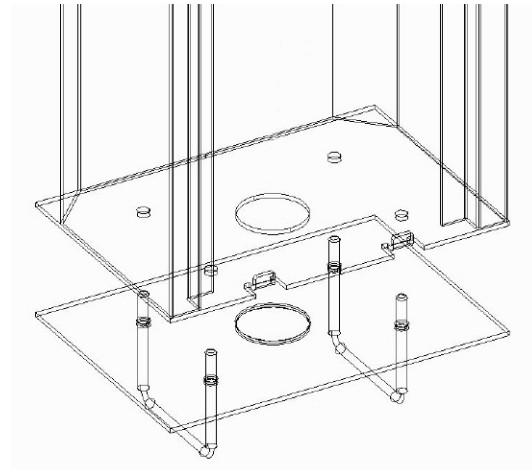
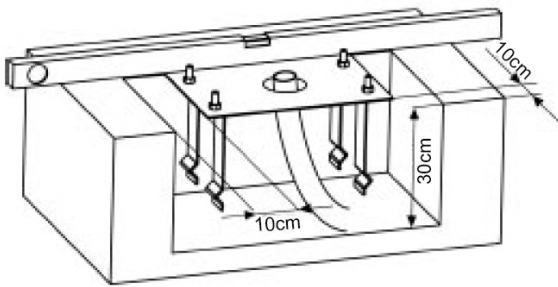

Fig. 4 - Fixing the barrier body

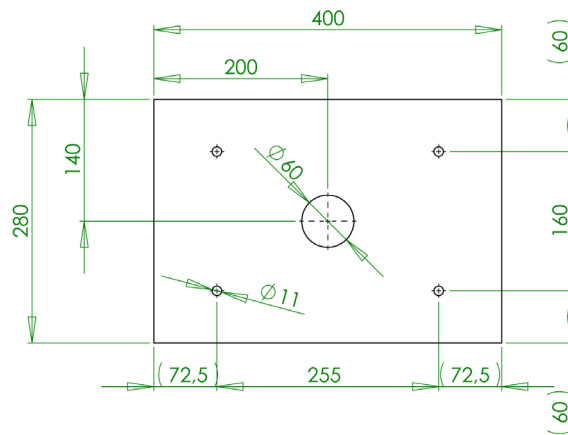

Fig. 5 - Fixing round bar/square bar

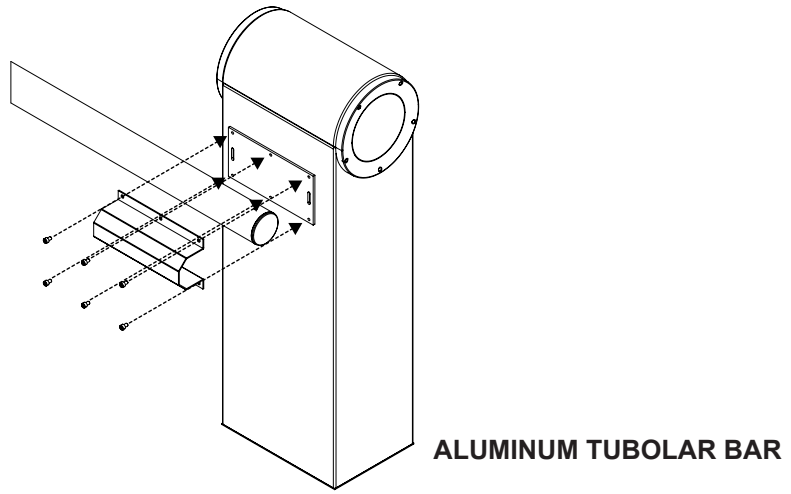

Fig. 6 - Adjustment of bar angle

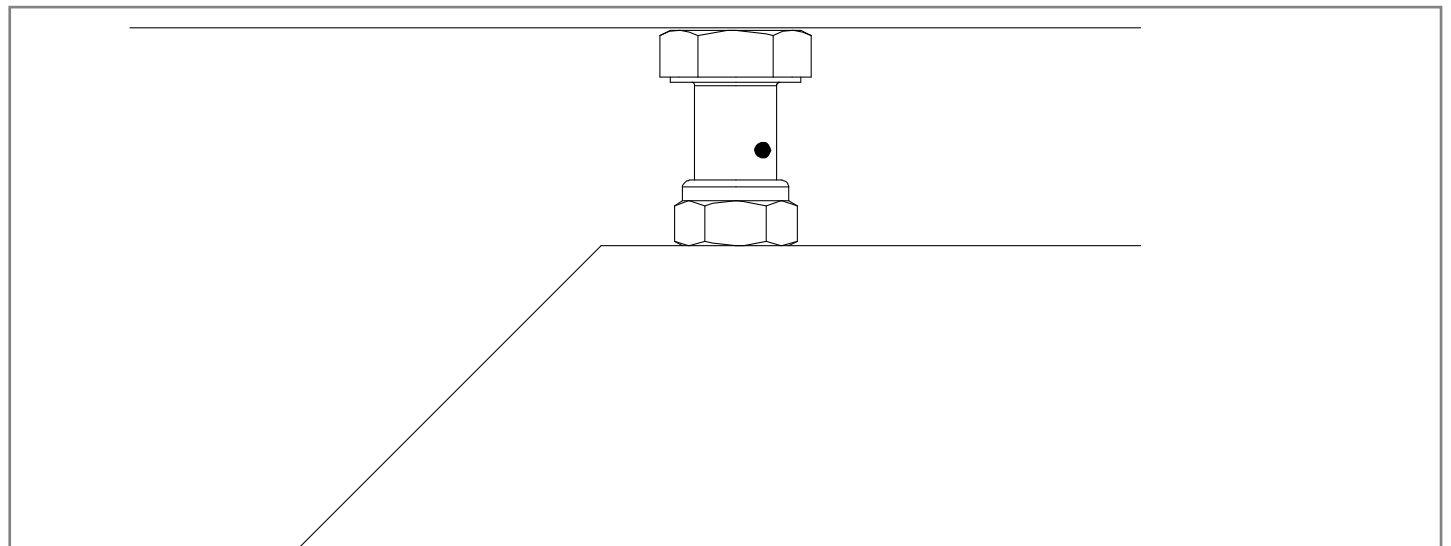

Fig. 7 - Inversion of direction of opening and balancing

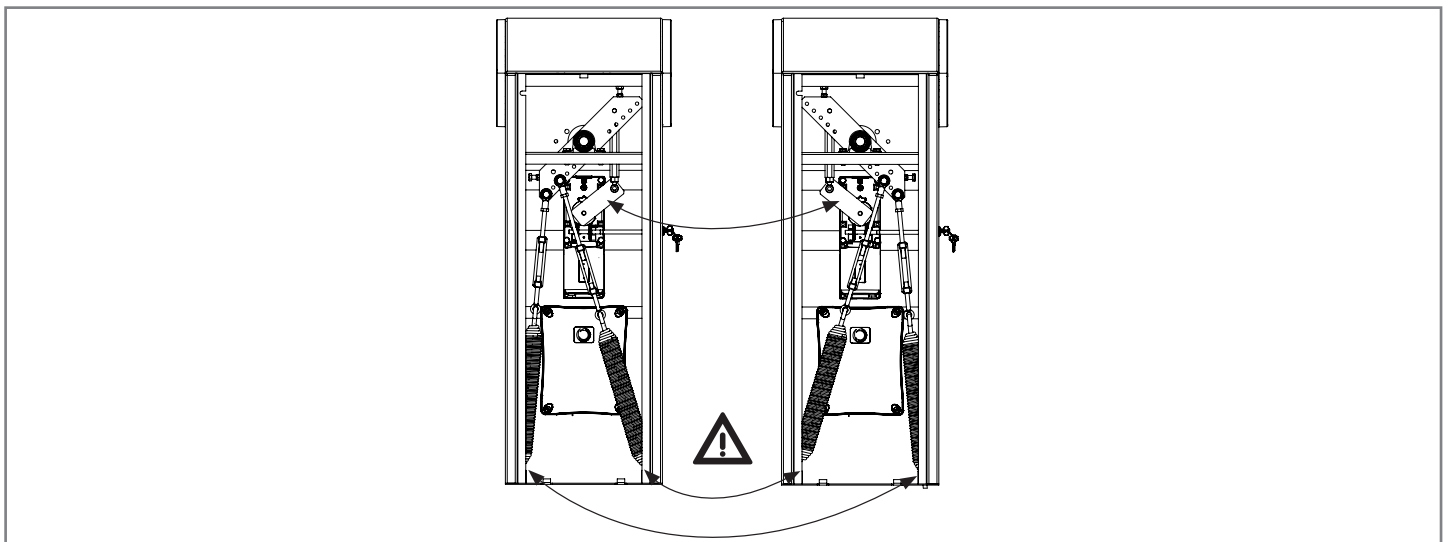
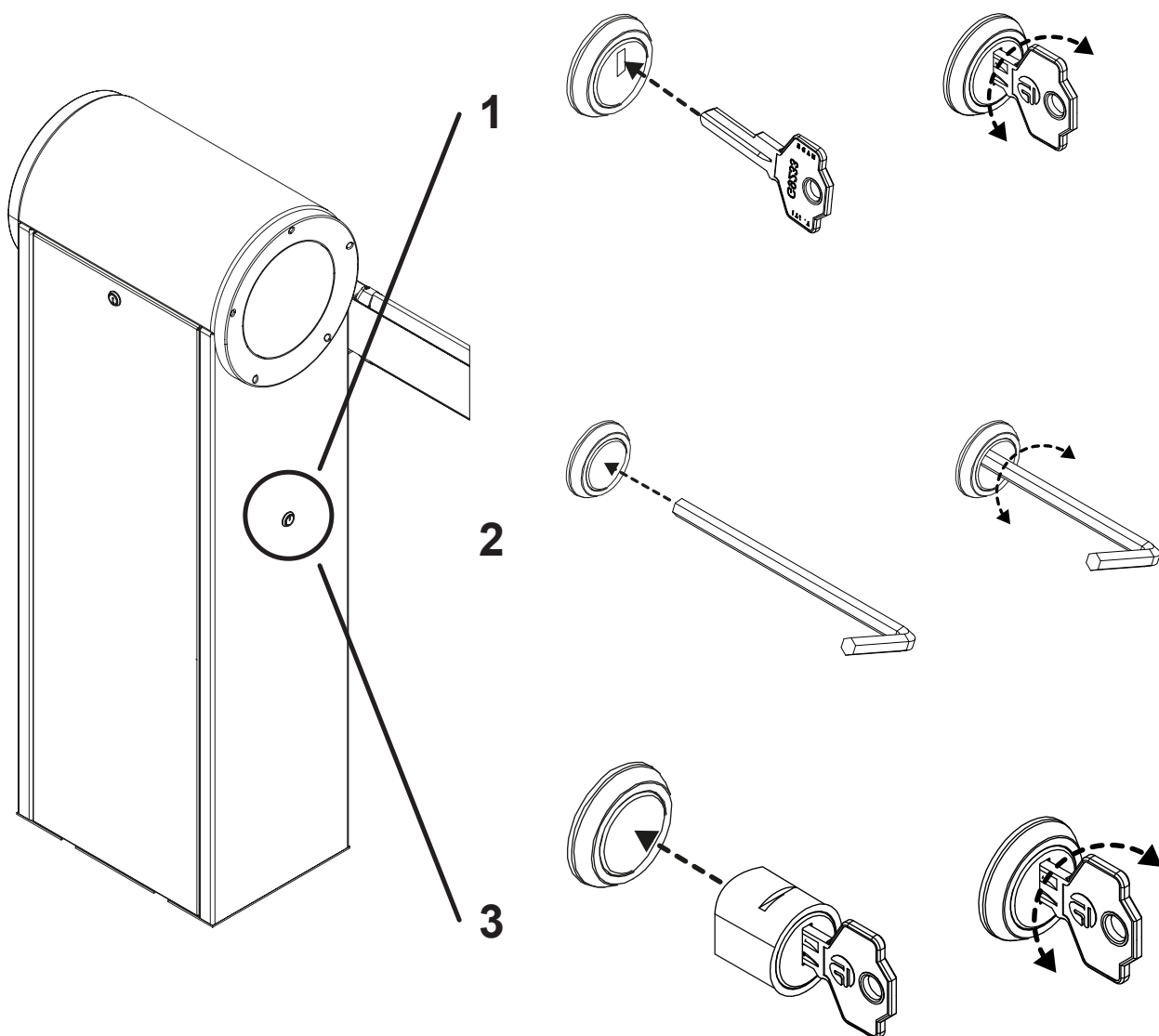

Fig. 8 - Release system



WARNING: WHEN UNLOCKING THE BAR, THE BAR CAN FALL OR RAISE. DO NOT STAND BELOW THE BAR.

BAR BALACING ALT6K

LEGENDA

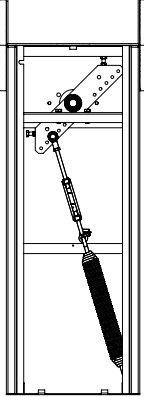

example of spring type and position:
3D1

3=HOLE NUMBER
D=SPRING POSITION
1=SPRING TYPE

HOLE NUMBER

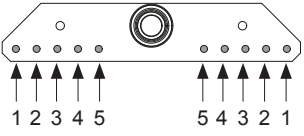

1 2 3 4 5 5 4 3 2 1

SPRING POSITION
V=vertical position
D=diagonal position

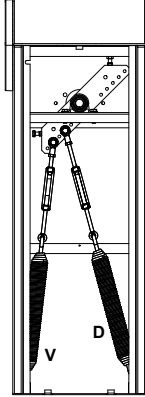



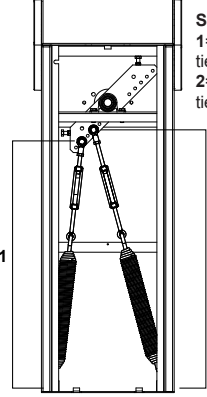

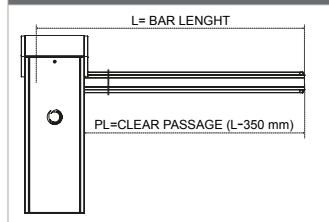

SPRING TYPE
1=spring + short tie rod
2=spring + long tie rod









BAR + RUBBER

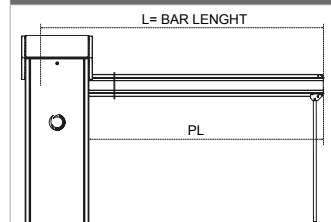

L= BAR LENGHT (mm)	POSITION
1000-1500	NO SPRING *
1501-2000	NO SPRING *
2001-2500	NO SPRING *
2501-3000	 4D2
3001-3500	 4D2
3501-4000	 3D1
4001-4500	 3D1
4501-5000	 3D1
5001-5500	 3D1
5501-6000	 3D1





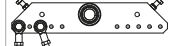

BAR + RUBBER + MOBILE STAND

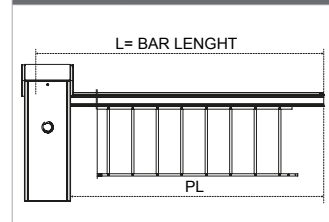

L= BAR LENGHT (mm)	POSITION
-	-
-	-
-	-
2501-3000	 4D2
3001-3500	 3D1
3501-4000	 3D1
4001-4500	 3D1
4501-5000	 3D1
5001-5500	 3D1
5501-6000	 3D1

BAR + RUBBER + FENCE (1x)

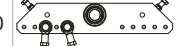

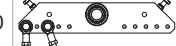
L= BAR LENGHT (mm)	POSITION
-	-
-	-
-	-
2501-3000	 4D2
3001-3500	 3D1
3501-4000	 3D1
4001-4500	 3D1
4501-5000	 3D1
5001-5500	 3D1
5501-6000	 3D1

BAR + RUBBER + FENCE (2x)

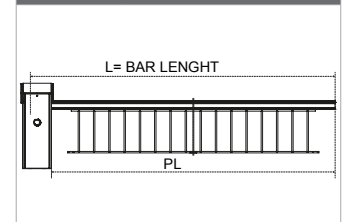

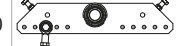
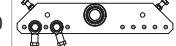
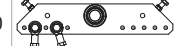
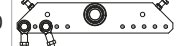
L= BAR LENGHT (mm)	POSITION
-	-
-	-
-	-
-	-
-	-
3501-4000	 3D1
4001-4500	 3D1
4501-5000	 3D1
5001-5500	 3D1
5501-6000	 3D1

* Without spring bar will fall when unlocked. From 1 to 4 meter bar use ALT4.

BAR BALACING ALT6K

BAR + RUBBER + FENCE (3x)

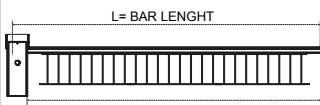

L= BAR LENGHT (mm)	POSITION
-	-
-	-
-	-
-	-
-	-
-	-
-	-
-	-
5001-5500	
5501-6000	

BAR + FENCE (1x) + MOBILE STAND

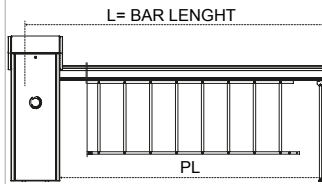

L= BAR LENGHT (mm)	POSITION
-	-
-	-
-	-
2501-3000	
3001-3500	
3501-4000	
4001-4500	
4501-5000	
5001-5500	
5501-6000	

BAR + FENCE (2x) + MOBILE STAND

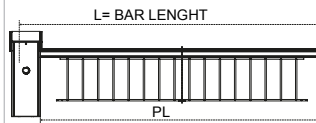

L= BAR LENGHT (mm)	POSITION
-	-
-	-
-	-
-	-
-	-
3501-4000	
4001-4500	
4501-5000	
5001-5500	
5501-6000	

BAR + FENCE (3x) + MOBILE STAND

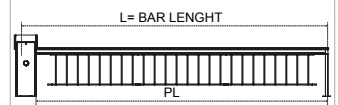

L= BAR LENGHT (mm)	POSITION
-	-
-	-
-	-
-	-
-	-
-	-
-	-
-	-
5001-5500	
5501-6000	

AST8 - 8 METER BAR BAR + MOBILE STAND

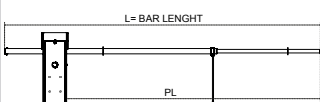

L= BAR LENGHT (mm)	POSITION
6000-6500	
6501-7000	
7001-7500	
7501-8000	
8001-8500	
8501-9000	

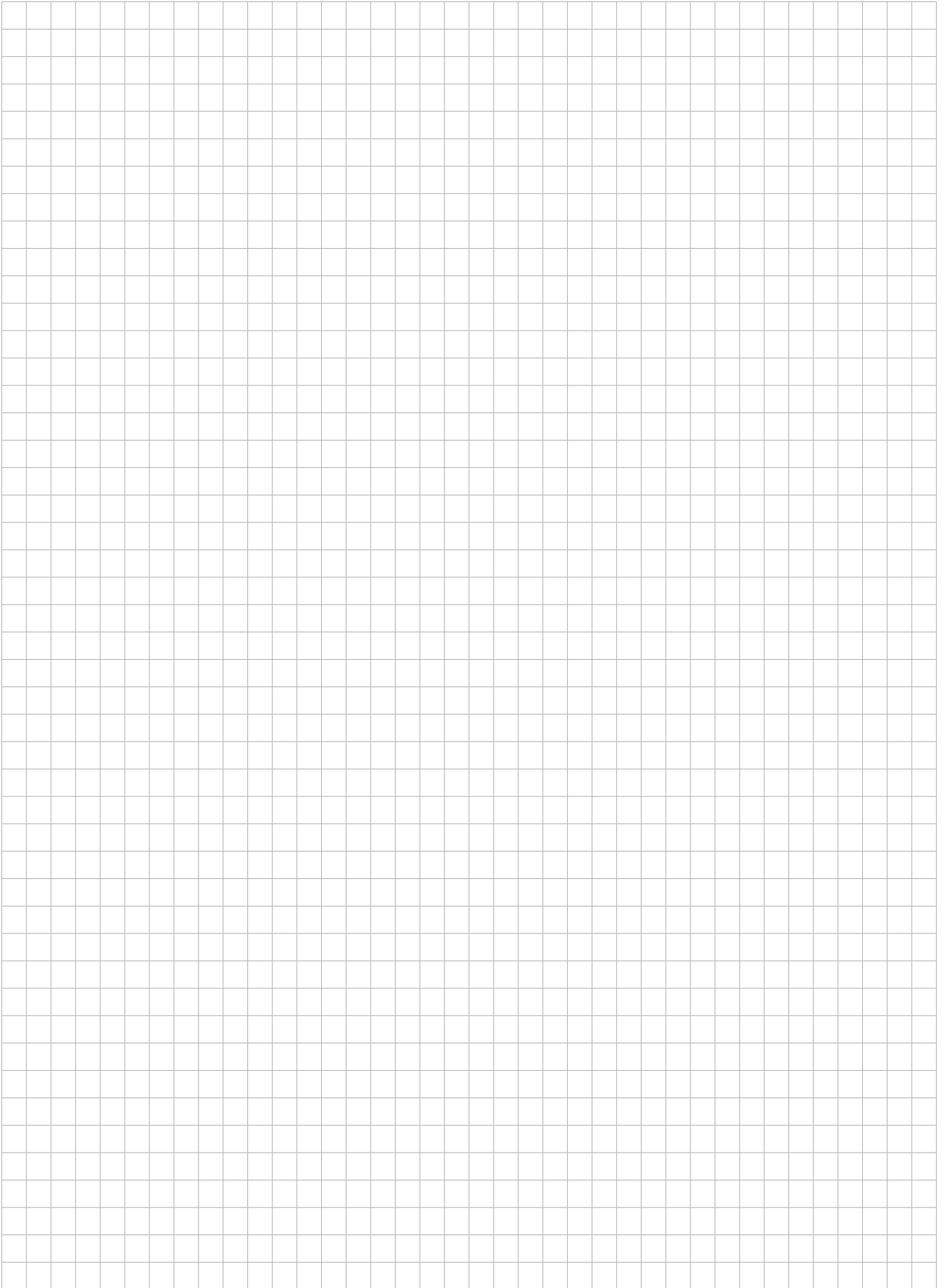

DICHIARAZIONE  DI CONFORMITA'

 **DECLARATION OF CONFORMITY**

Il sottoscritto Nicola Michelin, Amministratore Delegato dell'azienda
The undersigned Nicola Michelin, General Manager of the company

Key Automation srl, Via Alessandro Volta, 30 - 30020 Noventa di Piave (VE) – ITALIA

dichiara che il prodotto tipo:
declares that the product type:

ALT

Barriera elettromeccanica irreversibile con asta da 4m o 6m
Electromechanical irreversible barrier with 4m or 6m rod

Models:
Models:

900ALT424, 900ALT424K, 900ALT624, 900ALT624K

E' conforme a quanto previsto dalle seguenti direttive comunitarie:
Is in conformity with the following community (EC) regulations:

Direttiva macchine / *Machinery Directive 2006/42/EC*
Direttiva bassa tensione / *Low voltage Directive 2006/95/EC*
Direttiva compatibilità elettromagnetica / *EMC Directive 2004/108/EC*
Direttiva R&TTE / *R&TTE Directive 1999/5/EC*

Secondo quanto previsto dalle seguenti norme armonizzate:
In accordance with the following harmonized standards regulations:

EN 55014-1:2006 + A1:2009 + A2:2011
EN 55014-2:1997 + A1:2001+ A2:2008
EN 61000-3-2:2006 + A1 + A2:2009
EN 61000-3-3:2008
EN 60335-1; EN 60335-2
EN 300220-1:2012; EN 300220-2:2012
EN 301489-1:2011; EN 301489-3:2002
EN 62233:2008

Dichiara che la documentazione tecnica pertinente al prodotto è stata redatta conformemente a quanto previsto dalla direttiva 2006/42/CE Allegato VII parte B e verrà fornita a fronte di una richiesta adeguatamente motivata dalle autorità nazionali.

Declares that the technical documentation is compiled in accordance with the directive 2006/42/EC Annex VII part B and will be transmitted in response to a reasoned request by the national authorities.

Noventa di Piave (VE), 05/08/14

Amministratore Delegato
General Manager
Nicola Michelin



Key Automation S.r.l. a socio unico
Via A. Volta, 30
30020 Noventa di Piave (VE)
P.IVA 03627650264 C.F. 03627650264
info@keyautomation.it

Capitale sociale 100.000 € i.v.
Reg. Imprese di Venezia 03627650264
REA VE 326953
www.keyautomation.it



Organizzazione con sistema di gestione certificato
ISO 9001:2008

Key Automation S.r.l.

Via A. Volta 30 - 30020 Noventa di Piave (VE)
T. +39 0421.307.456 - F. +39 0421.656.98
info@keyautomation.it - www.keyautomation.it

Instruction version
580ISALT REV.02