

# Phase-In • MOOVI BT

High-speed, low voltage road barrier



## ▶ Plus



### LOW VOLTAGE MOTOR

Greater number of consecutive cycles, intensive duty and greater boom speed.



### PROTECTION DEGREE IP54

Total protection from water and dust.

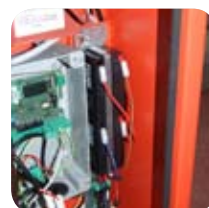

### BACKUP BATTERIES

Option of connecting the battery kit to ensure operation even in the event of a power outage.

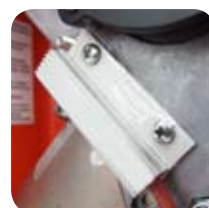

### LOW TEMPERATURE OPERATION

Using an optional heater, the barrier can operate at temperatures as low as -40°C.

▶ Product reference	Description	Availability
P940035 00002	MOOVI 30 BT	April 15th 2010
P940036 00002	MOOVI 50 BT	April 15th 2010

## ▶ Size

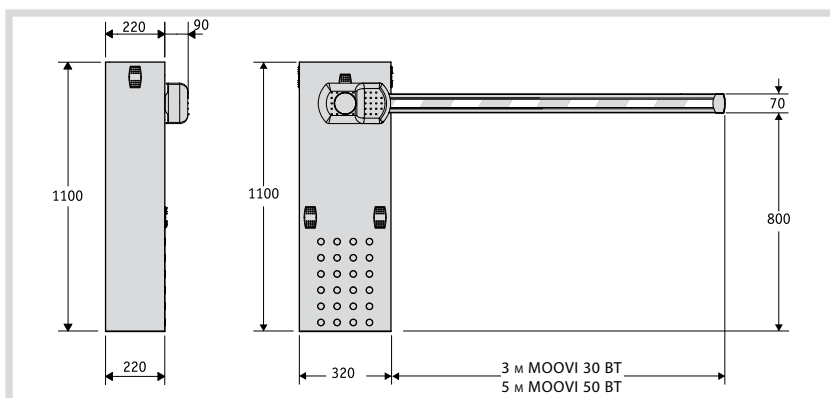

## ▶ Advantages

### LOW VOLTAGE ELECTRIC MOTOR:

Thanks to the 24 V power supply, the MOOVI BT 30 and 50 allow up to 800 consecutive cycles to be carried out with opening times of up to 2 seconds (greater slowing). The positioning in the limit switch, along with the speed control and obstacle detection are managed by an encoder technology based electronic system.

### IP54:

there are no ventilation louvers in the enclosure meaning that the protection degree of the MOOVI BT 30 and 50 barriers is IP54, making it possible to install it anywhere, with maximum protection of internal parts against water and dust.

### COMPLETE RANGE OF ACCESSORIES:

All the specific accessories for the MOOVI barriers are compatible with the BT versions. These therefore include supports for photocells, lights, rubber profiles, etc.. Furthermore, the BT versions also boast the option of an installation of a battery kit and thermostatic heater to allow operation down to environment temperatures of -40°C.



# Phase-In • MOOVI BT

High-speed, low voltage road barrier

## ▶ Installation example

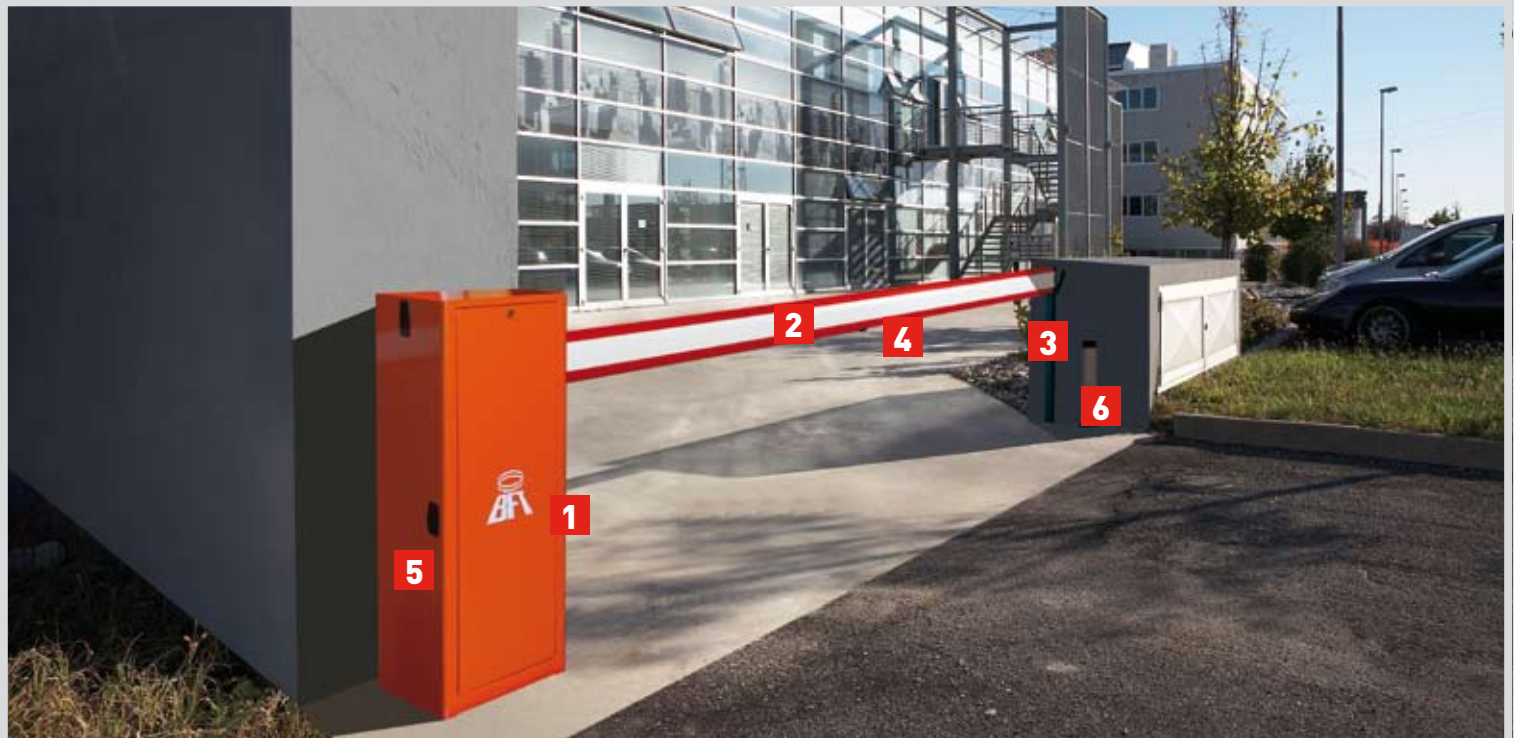

**1** Operator

**2** Boom

**3** Rest rod

**4** Rubber profile

**5** Photocell support

**6** Set of photocells

## ▶ Accessories



**P120017 - MOOVI BT BAT**  
Backup battery kit for MOOVI BT.



**P120018 - THERMO**  
Thermostatic heater for MOOVI, MICHELANGELO barriers down to environment temperatures of -40°C.



**P123023 - RWS**  
Wall support for RAY X flashing lights



**D113719 00003 - RAY X**  
Flashing light with built-in antenna for 24 V motors

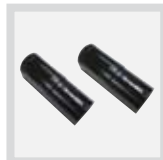

**P111452 - CELLULA 180**  
Set of adjustable photocells (180° horiz./ 20° vert.) For outdoor use (range 30 m). Power supply 24V ac/dc



**P111273 - CELLULA 130**  
Set of self-aligning photocells for outdoor use (range 30 m). Power supply 24V ac/dc

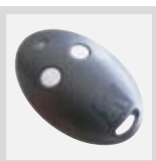

**D111750 - MITTO 2**  
Two-channel 433 MHz rolling code transmitter

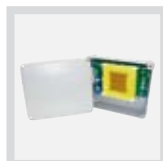

**D111457 00002 - PASSY ANTENNA MONO**  
One-way 2.45 GHz illuminator antenna. Together with the PASSY TRANSPONDER, when in the area covered by the antenna. Control of the automation in one direction only.



**D111457 00001 - PASSY ANTENNA OMNI**  
Omnidirectional 2.45 GHz illuminator antenna. Together with the PASSY TRANSPONDER, it activates the gate operator in the area covered by the antenna. Control of the automation both in and out.



**D111456 - PASSY TRANSPONDER**  
Dual frequency, 2.45 GHz active transponder for the detection of PASSY ANTENNA and 433 MHz for the command to the operator